

HYFOR & Smelter Industrial Prototype

INCITE

1st Sectoral Workshop
Iron and Steel

May 13th -15th, 2025

Dr. Alexander.Fleischanderl, CTO

Confidential © Primetals Technologies 2021-2025. All rights reserved.

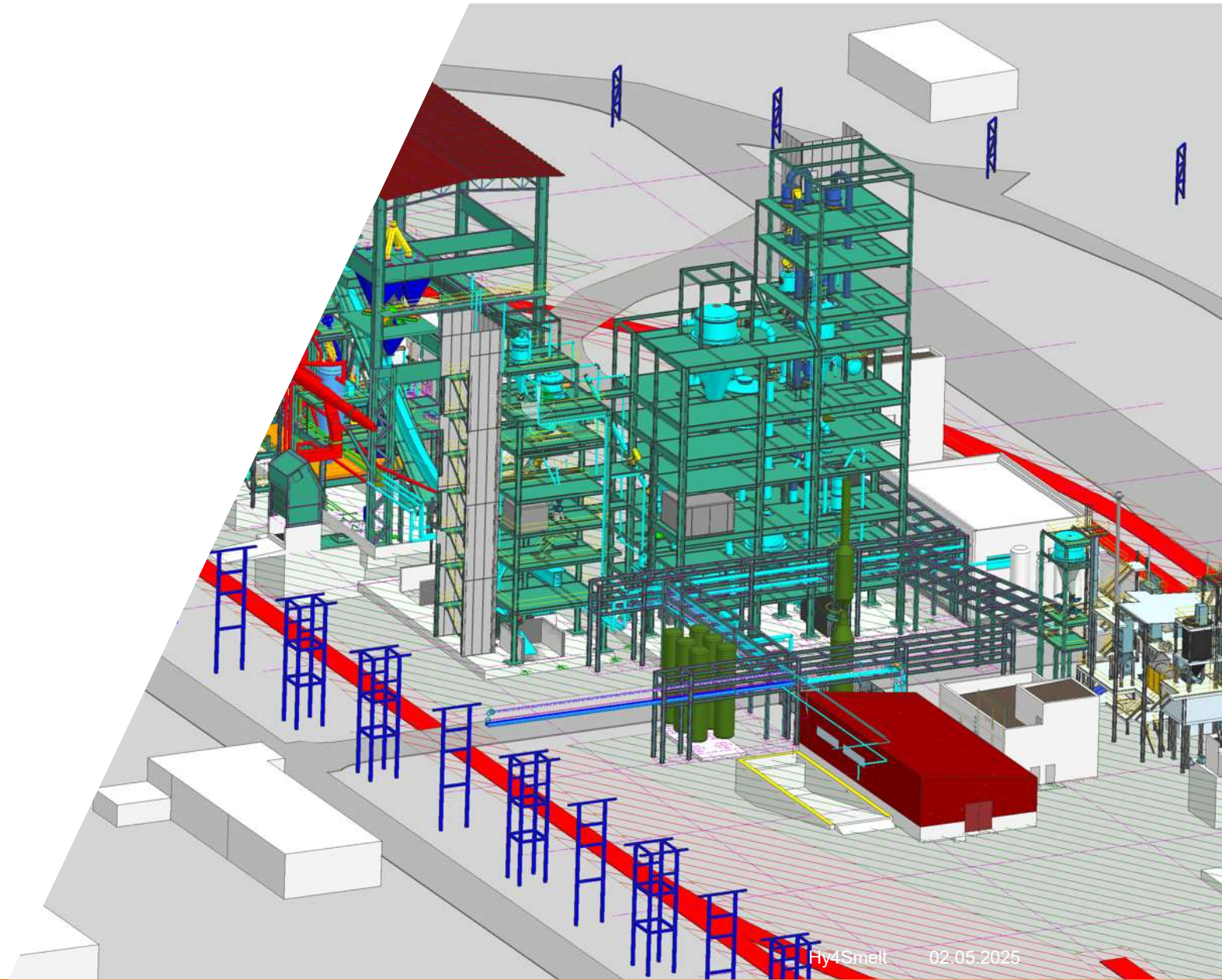

Introduction

■ **Project:**

Investment, installation and 3-years operation of the **Hy4Smelt** industrial prototype plant.

■ **What is Hy4Smelt**

Hy4Smelt is a new development to replace the blast furnace process using a HYFOR[®] H₂-based **Fluidized Bed Reactor** cascade for the pre-reduction in combination with a **Smelter** for the final-reduction, melting, carburization, and slag formation to produce alternative **green iron** and slag with similar quality to a BF.

■ **Purpose of the project**

A significant **reduction of Scope 1 and 2 CO₂ emissions**, promote circularity, twin transition and the energy efficiency.

■ **Start TRL 5 – End TRL 7-8**

2015-19: Simulation, Lab-testing
2020-24: Pilot Plant (~300 kg/h)

■ **Partners**

Primetals Technologies, **voestalpine** and **Rio Tinto** cooperate to install and operate a **HYFOR** combined with a **Smelter** industrial prototype plant.

Hy4Smelt Process

Hy4Smelt is a ground-breaking new process combining direct reduction (process is called **HYFOR[®]**) using 100% Hydrogen as reducing agent and electrified smelting (furnace is called **Smelter**).

HYFOR = Hydrogen based Fine Ore Reduction

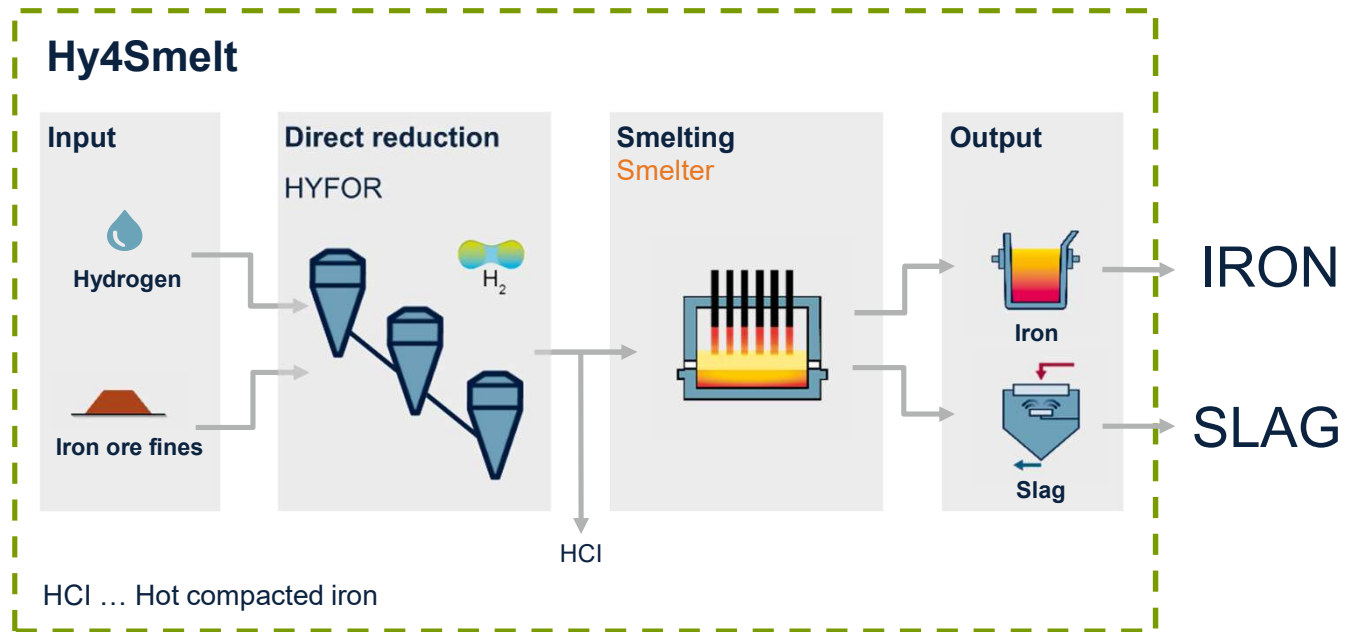

If operated with green energy and bio-carbon Hy4Smelt allows for **carbon neutral iron production**

Hy4Smelt - Industrial Prototype Plant

- Installation of **HYFOR[®]**, **Smelter** and all required auxiliary facilities.
- Designed for a maximum capacity of 3 ton of green iron per hour.
- Continuous operation from iron ore feed to pig iron (or DRI/HBI) and slag granulation.
- “Green metallics” – reduction is fully based on green H₂; all heating's and power consumption based on renewable electricity.

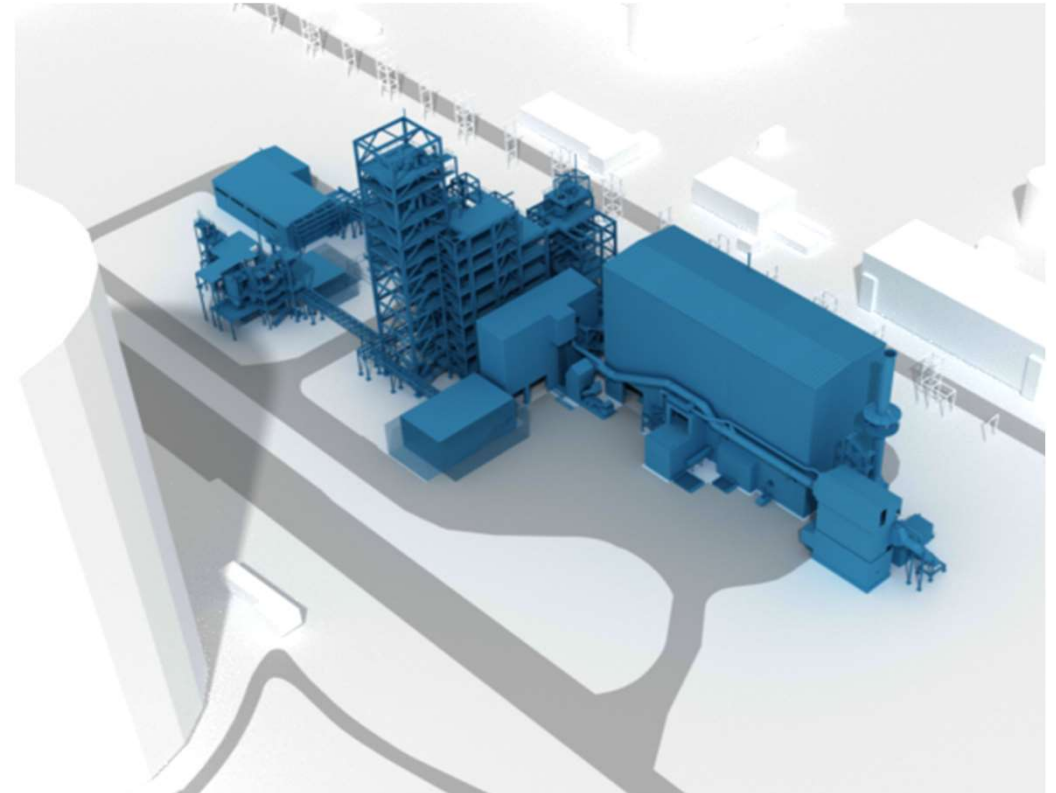

3D Model of Hy4Smelt plant

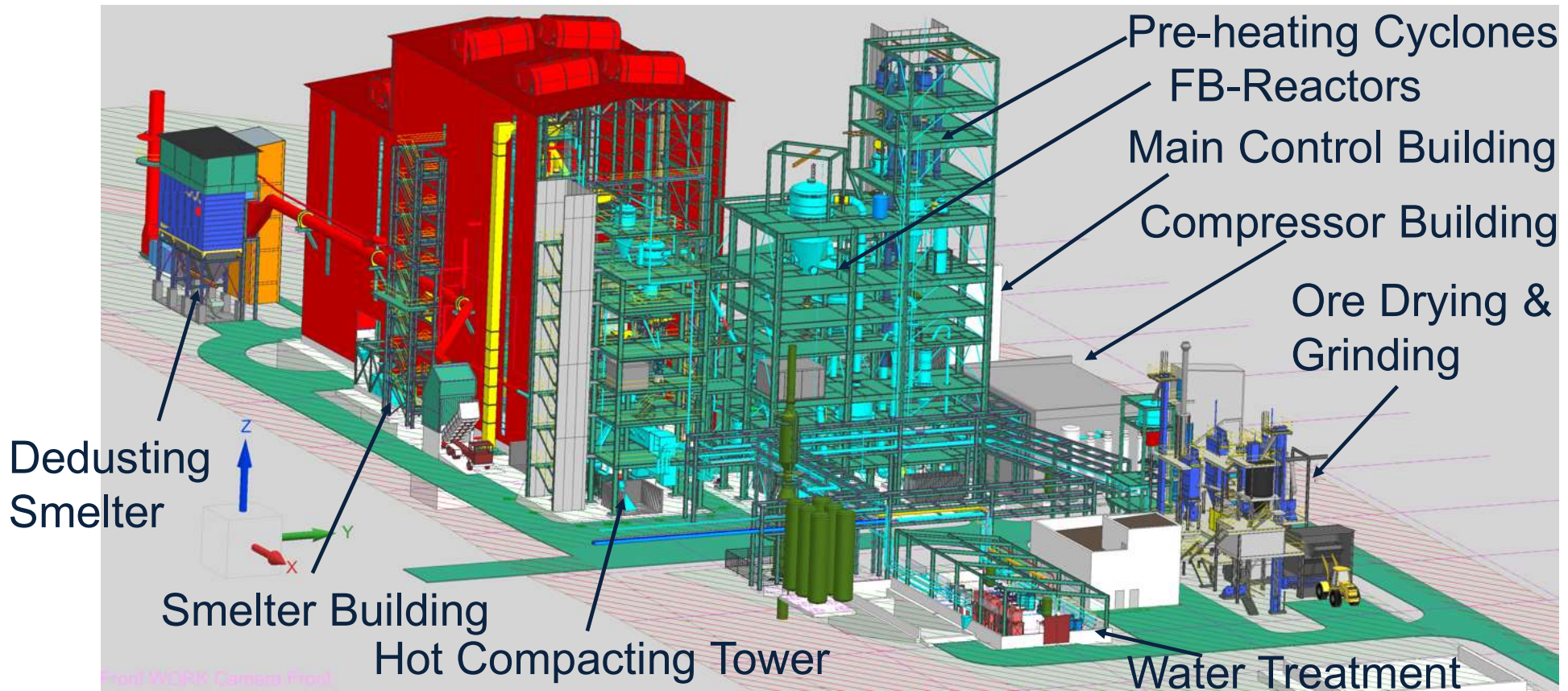

Flowsheet Industrial Prototype plant

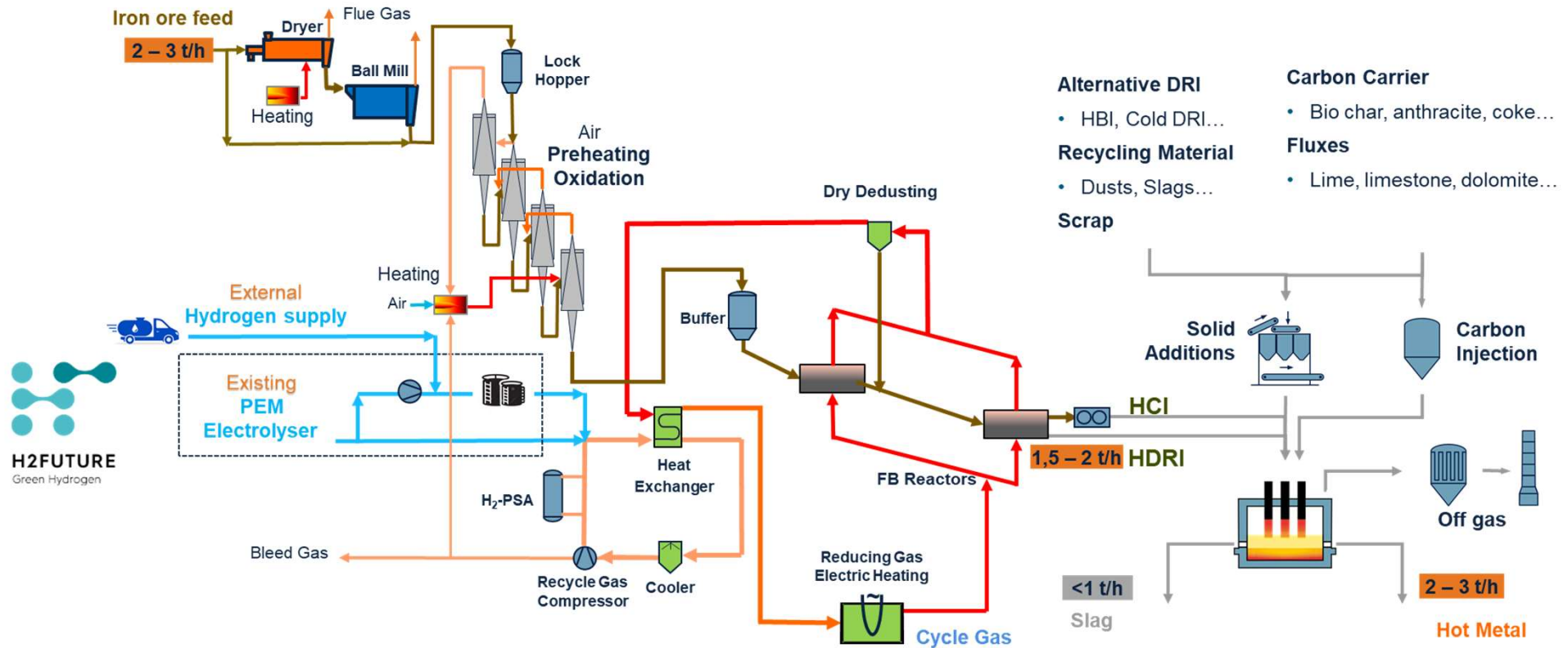

Iron ore products by quality

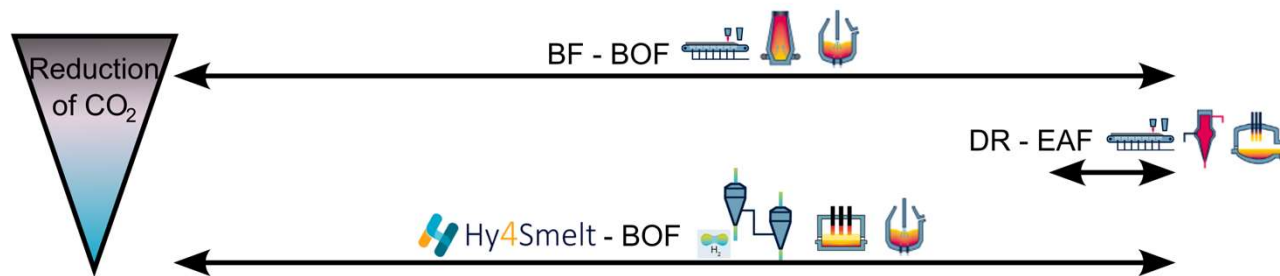
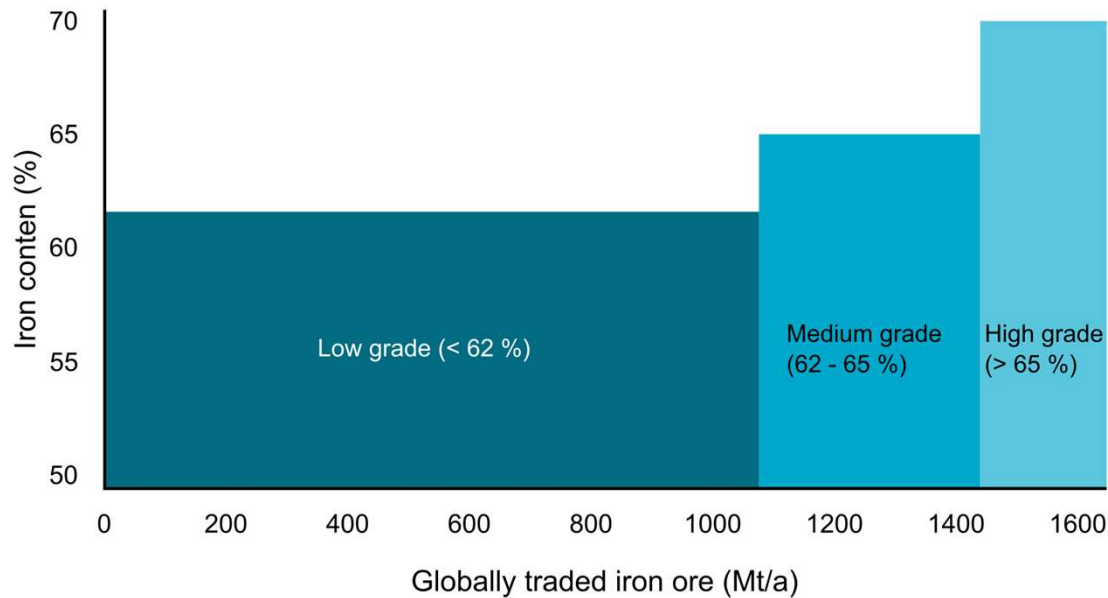

- **Majority of iron ores** available globally for iron production are fine ores with **Fe < 65 %**
- **EAF process not suitable for melting DRI/ HBI with high slag quantities** of up to 300 kg/t
- **Iron ores with Fe > 65 %** will not be able to replace low/medium grade ores in the future

Process Routes for Transitioning to Net-Zero

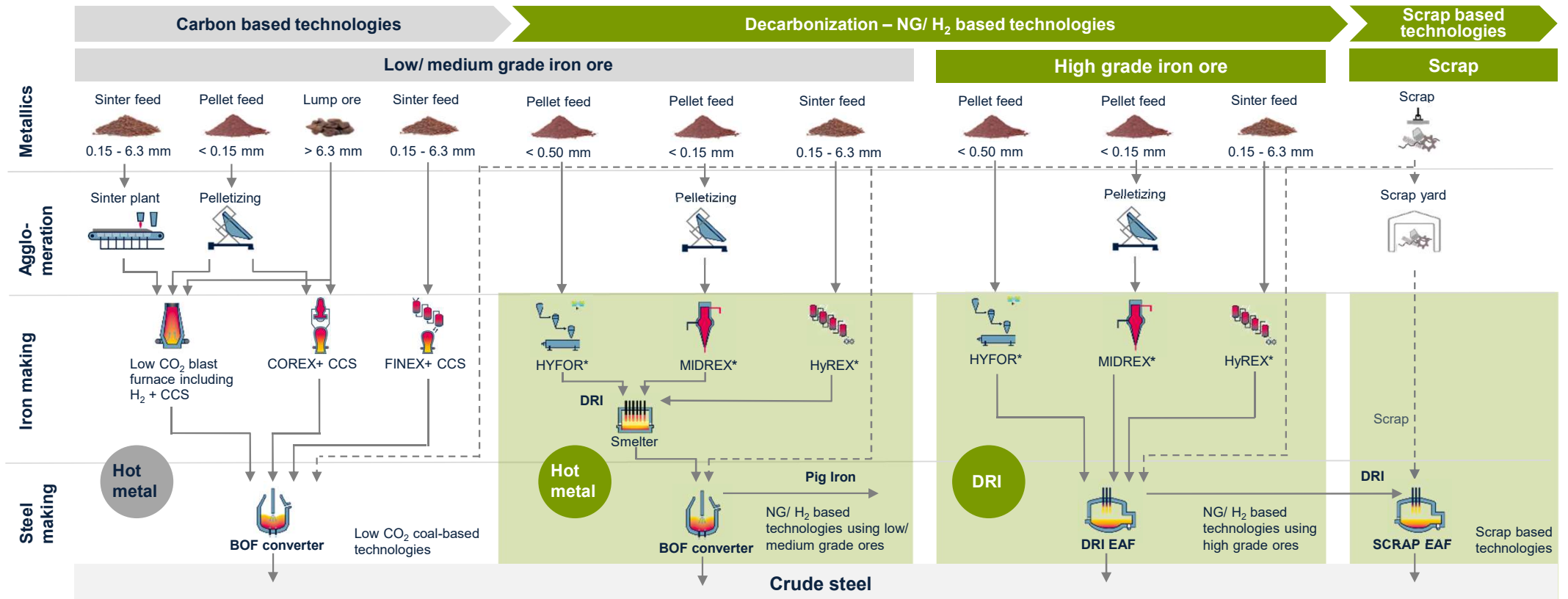

*MIDREX, HyREX and HYFOR are registered trademarks of Midrex Corporation, POSCO and Primetals Technologies respectively

Existing HYFOR[®] Pilot plant at voestalpine Donawitz

- Verify performance of **Fluidized-bed** and **preheating/oxidation cyclone** under real Hydrogen operating conditions
- Direct reduction of **magnetite/hematite/goethite iron ore fines with H₂** in fluidized bed reactor at **700 °C** up to a **metallization degree of 98%**
- Typical grain size: **100 % < 150 μm**
Max. grain size: **< 500 μm**



Existing HYFOR[®] Pilot plant and Awards

- No Pelletizing required – Fines Feed (any type)
- Highest Yield (low temp./pressure Operation) – no dust byproduct
- Feed: ~ 1 t Iron Ore/Campaign
- Product: ~ 0.6 t DRI/HBI per Campaign
- Hydrogen Supply by Truck
- Advanced digital showcase



Primetals Technologies has received the “National Prize for Innovation” from the Austrian government. The prestigious award was presented at a special ceremony in Vienna, Austria, on November 16, 2023.



Primetals Technologies has received the “Federal Prize for Innovation” from the Upper Austrian government. The prestigious award was presented at a special ceremony in Linz, Austria, in November, 2024.

Targets Smelter

- Melting, de-slagging, and final reduction of DRI/HCI, with minor restriction concerning gangue content
- Hot metal evaluation for BOF/EAF steelmaking
- Use cases with different DRI's (fines or compacted) with different metallization and simulation of different energy input/melting: resistance heating + brush arc heating (Smelter) as well as arc heating (EAF operation)

Flowsheet Smelter

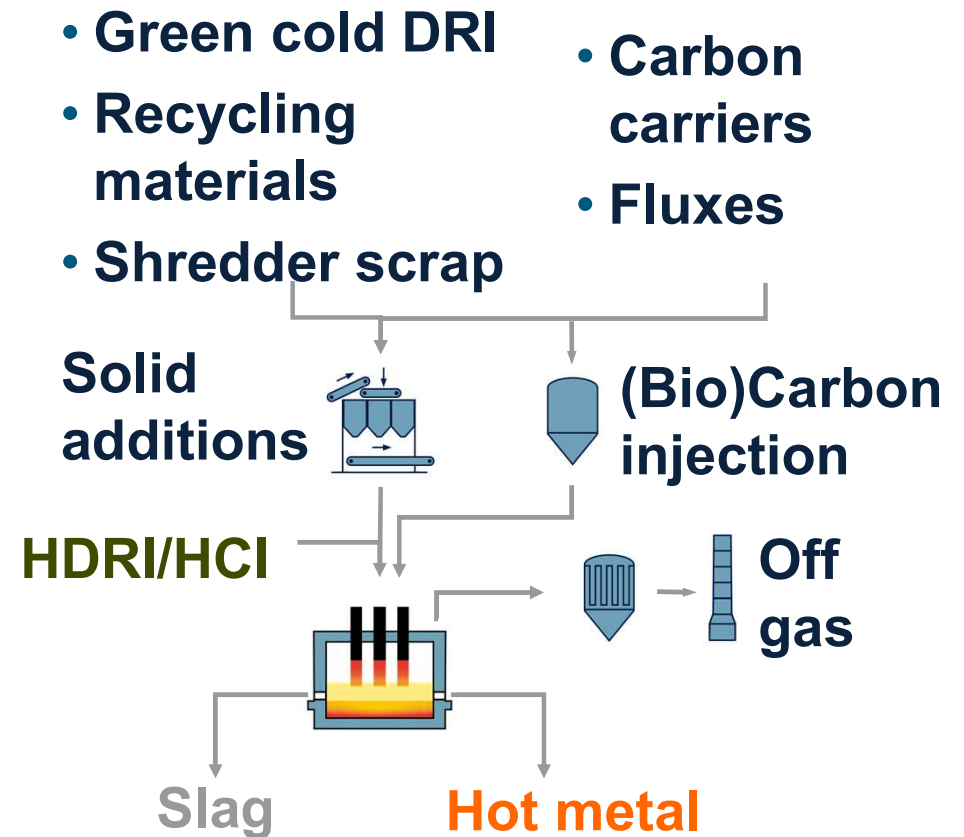

Funding Matrix

All values in MEUR

FUNDING MATRIX					
Funding	Applicant		FUNDING amount	%	Status
KPC	voestalpine	Smelter	30	80,0 %	Grant Agreement signed
aws	Primetals	Hyfor	22,25	25,0 %	Grant Agreement signed
Subtotal	National		52,25		
Funding	EU		FUNDING amount	Comment	
RFCS	Primetals Voestalpine Partners		18	RFCS cap	Grant Agreement signed
TOTAL			70,25		

Break-through Innovation Pathway

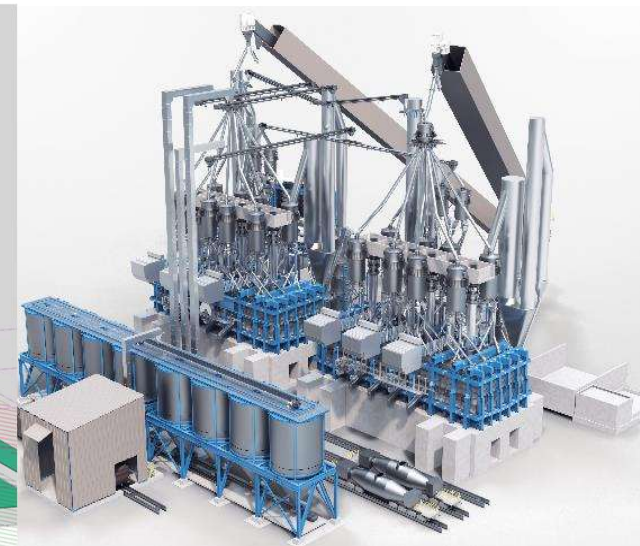
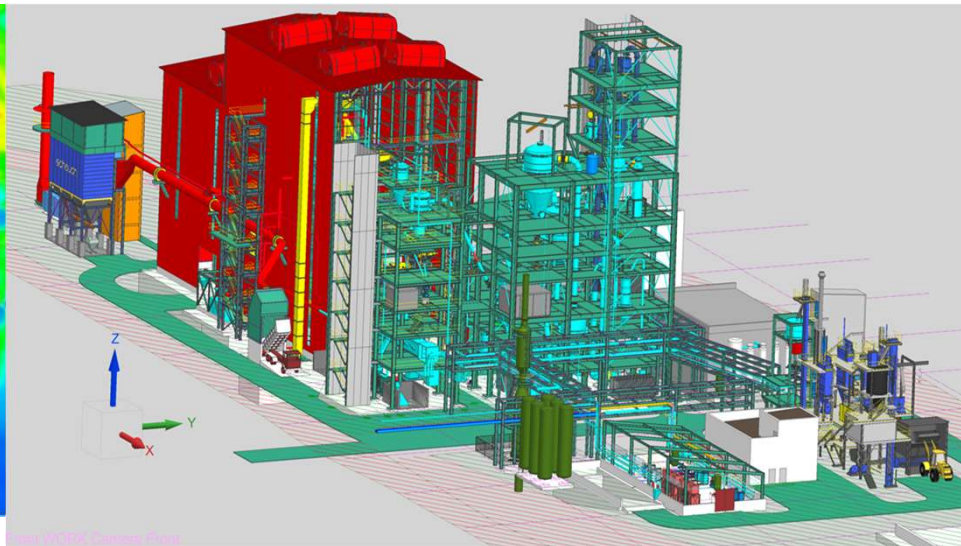
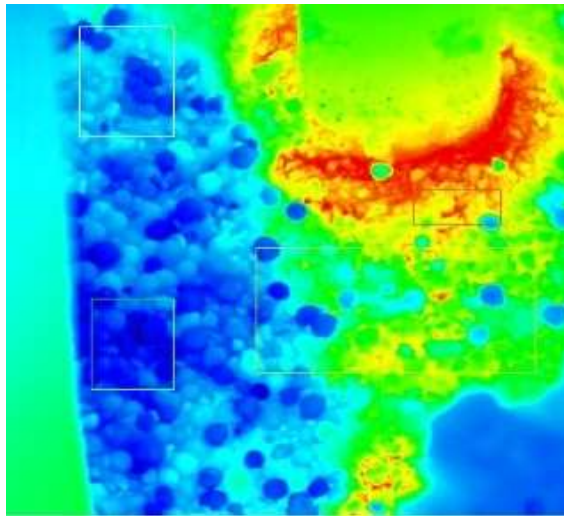



Dr. Alexander Fleischanderl
CTO & Member of the Executive Management
Global Head of Green Steel
alexander.fleischanderl@primetals.com

Primetals Technologies Austria GmbH
Turmstrasse 44
4031 Linz, Austria



THANK YOU